

# This presentation premiered at WaterSmart Innovations

[watersmartinnovations.com](http://watersmartinnovations.com)





# Secondary Water Systems for Landscape Irrigation

Issues and Opportunities



presented by

---

Douglas G. Macdonald, ASIC  
&  
Stephen W. Smith, F-ASIC



**Aqua Engineering, Inc.**

*Innovative Water Solutions*



# Presentation outline:

---

- ▶ Background and terminology
- ▶ Concepts and purposes
- ▶ Key components
- ▶ Implementation
- ▶ Sociological and political elements
- ▶ Case study
  - ▶ Highland Ditch Company  
2005 ASIC Excellence in  
Irrigation Merit Award:  
Planning and Analysis



# Background

---

- ▶ **Historical perspective of many mutual irrigation companies**
  - ▶ Roots in agriculture
  - ▶ 100-year plus perspective
  - ▶ Operational approach and management
  - ▶ Reliable organization
  - ▶ A rich history
- ▶ **Aqua Engineering's experience**
  - ▶ Utah, California, Colorado, Washington, Idaho



# Terminology

---

- ▶ “Secondary supply system” and “dual system” are interchangeable
- ▶ Raw water, non-potable water, ditch water, and agricultural water are the same



# Concepts and purposes

---



- ▶ **Why secondary supply?**
  - ▶ Utilizes water historically decreed for irrigation
  - ▶ Makes “good sense”
  - ▶ Likely lower unit cost to urban consumer
- ▶ **What have we learned?**
  - ▶ “Win-win” scenario
  - ▶ Success stories from canal companies and irrigation districts



# Ownership, management, & operation

---

- ▶ Options
  - ▶ Irrigation company or district
  - ▶ Potable water provider
  - ▶ City or Town (if different from potable water provider)
  - ▶ Developer or Homeowner's Association





# Typical residential secondary supply system

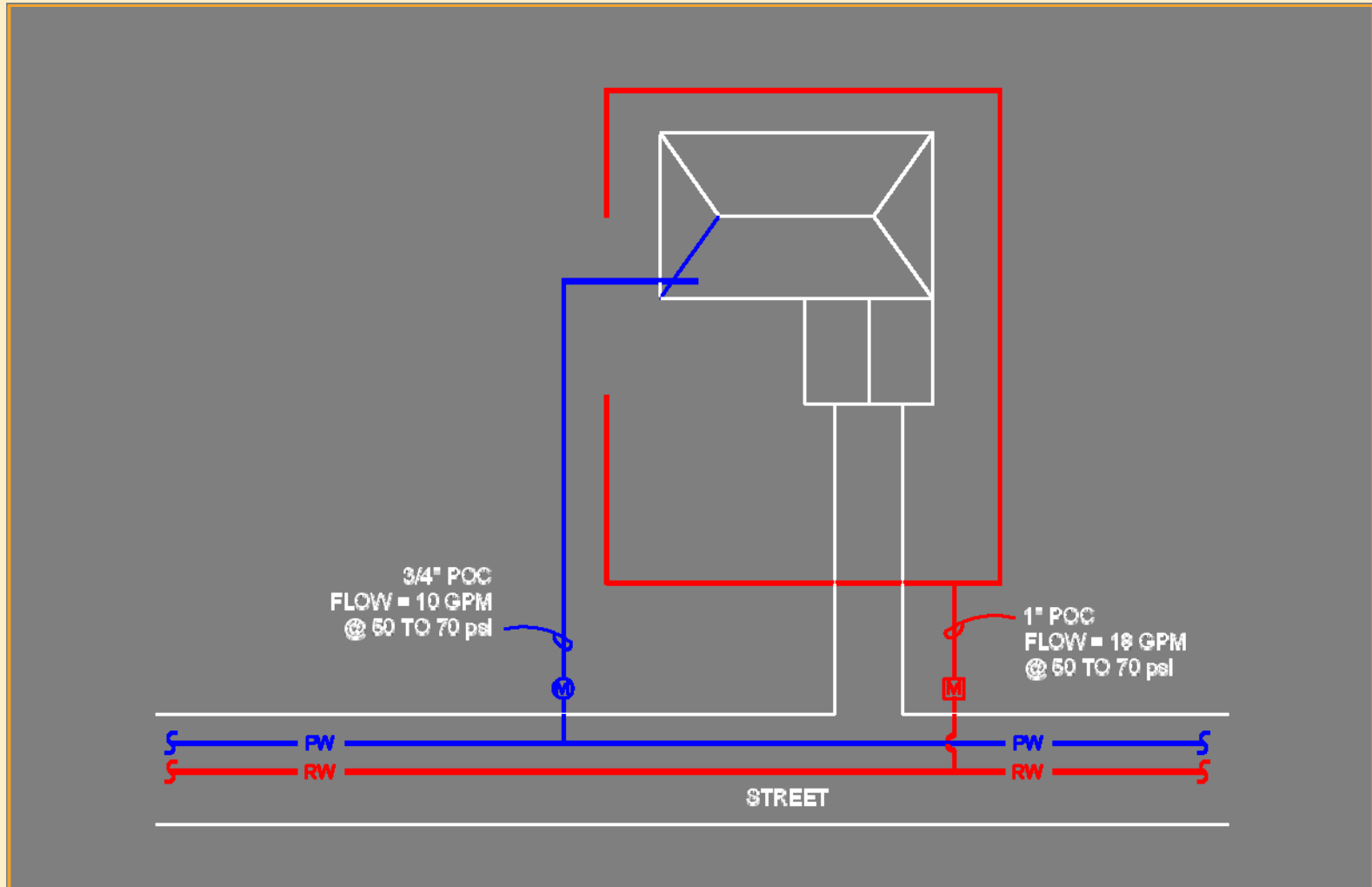

# Assessment structure (changing with the opportunity)

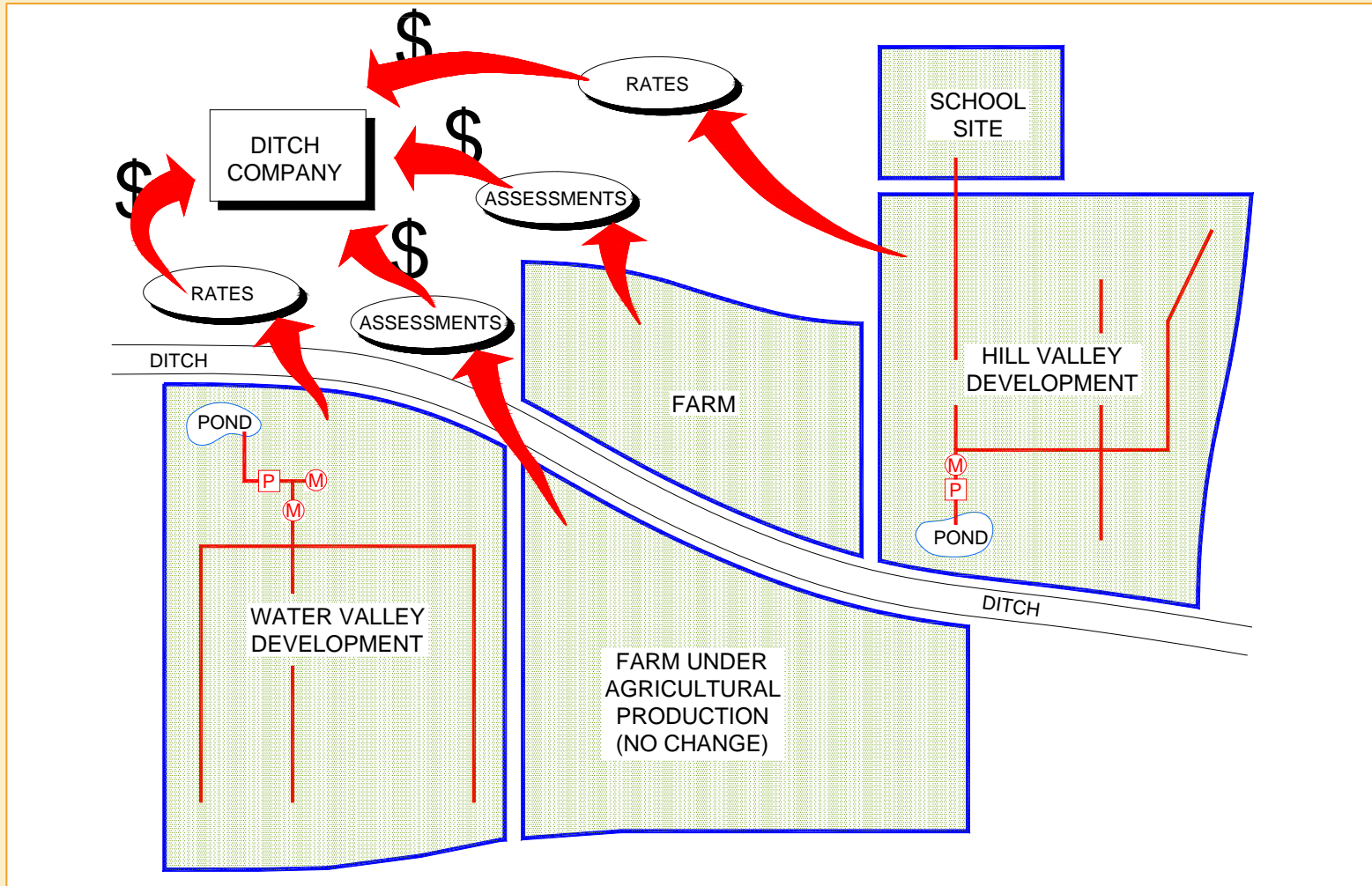

# Win-win benefits of secondary supply for the...

---

- ▶ **Developer**
  - ▶ Money savings
  - ▶ Historic water utilization
- ▶ **Potable water purveyor**
  - ▶ Water treatment capacity
- ▶ **Consumer**
  - ▶ Money savings
- ▶ **Ditch company**
  - ▶ Continues historic role
- ▶ **Community**
  - ▶ Long term benefits



# Key components

---

- ▶ Water rights
- ▶ Water storage
- ▶ Pumping and filtration system
- ▶ Pipe delivery infrastructure
- ▶ POC for each lot, both residential & commercial
- ▶ Residential and common area irrigation systems



# Water storage

---



# Pumping and filtration system

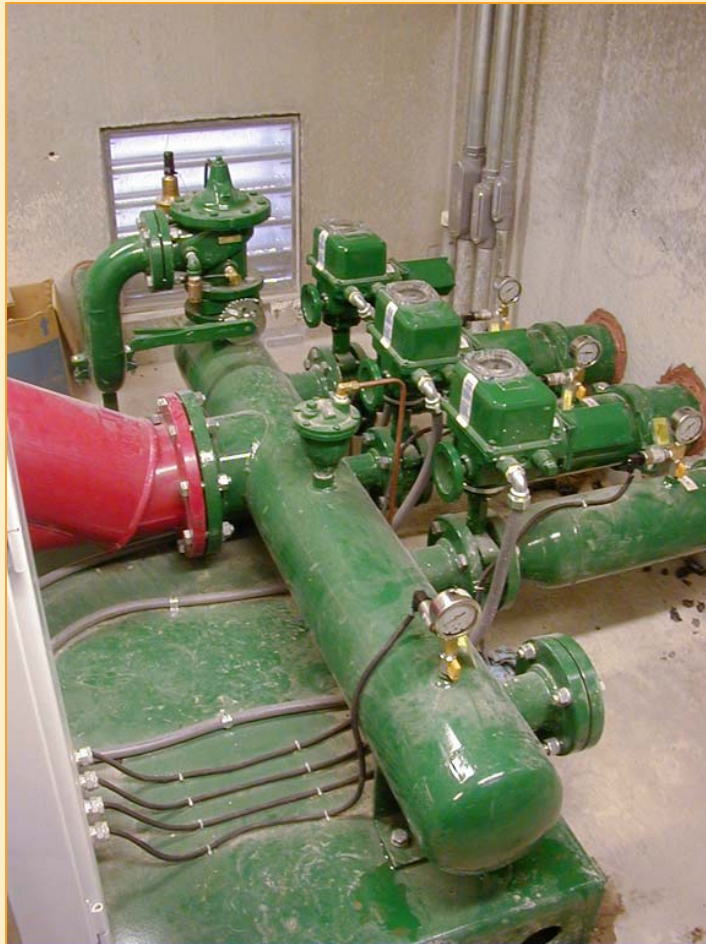

# Pipe and delivery infrastructure

---

Infrastructure piping



Valving



Air relief



# Point-of-connection (POC)

## Raw water point-of-connection

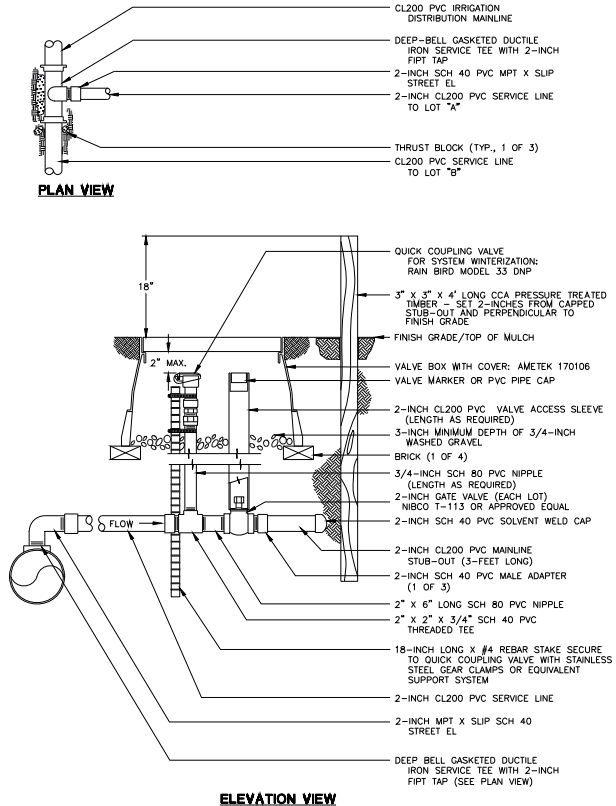



# Common area irrigation system

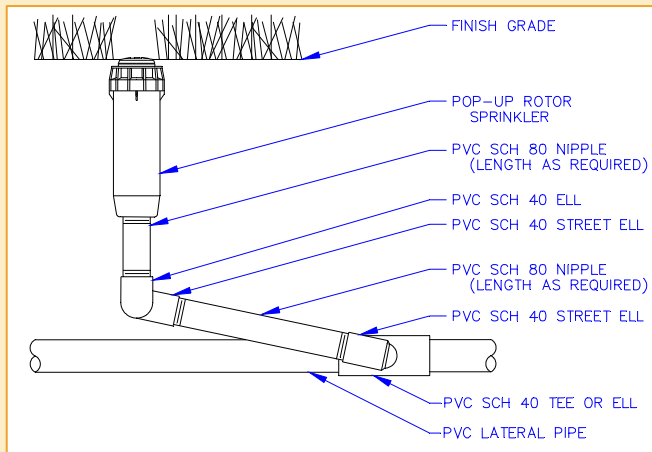

# Key questions

---



- ▶ Are the water rights sufficient in time, place and quantity?
- ▶ How much does secondary supply cost?
- ▶ Who will own, manage, and operate the secondary supply system?



# Water right

---

- ▶ Is a change in water right necessary?

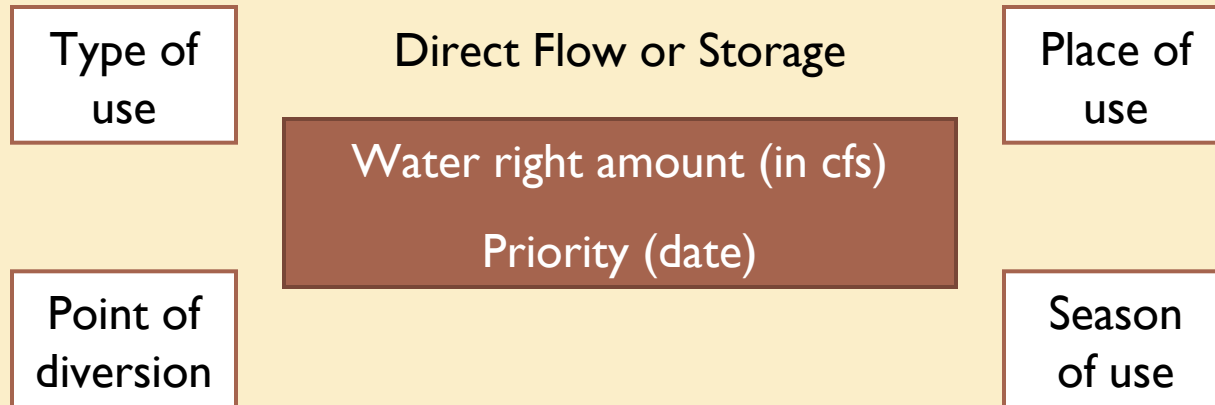

# Initial discussions

---

secondary supply  
ordinance

## Town

- motivation
- incentive

mutual irrigation  
company or irrigation  
district

- motivation
- water right
- historic perspective



# Agreement between Town and mutual irrigation company...

---

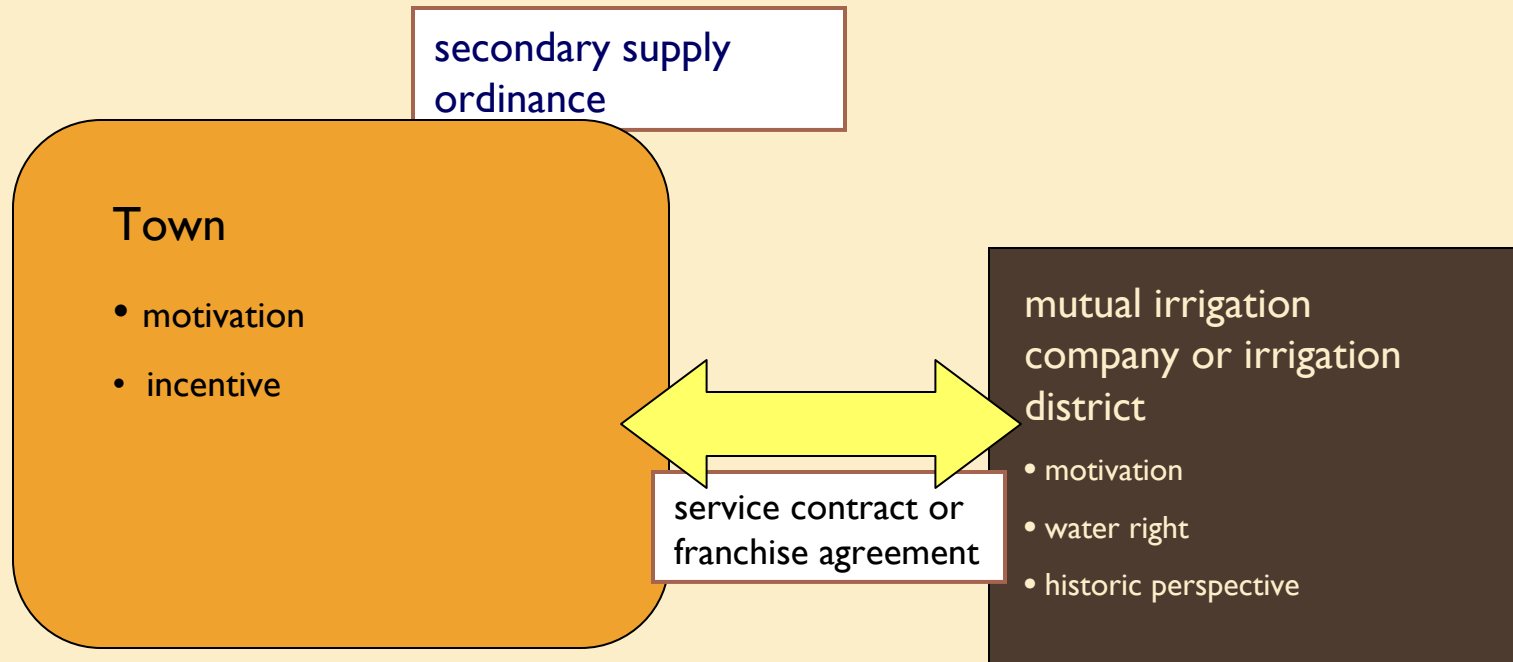

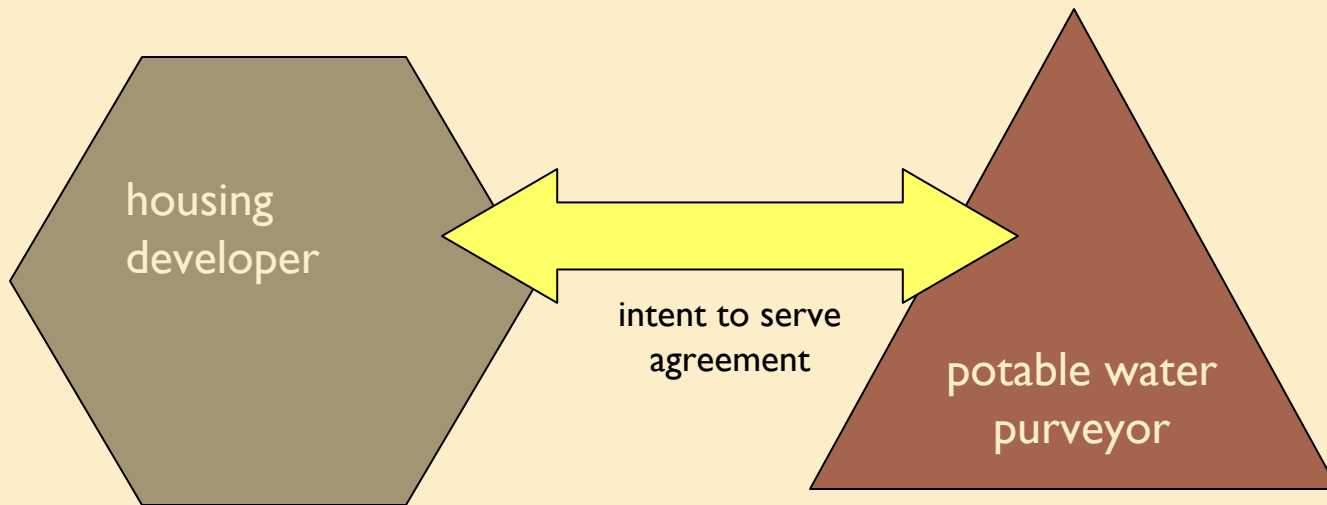

# Common agreement between Town and developer...

---

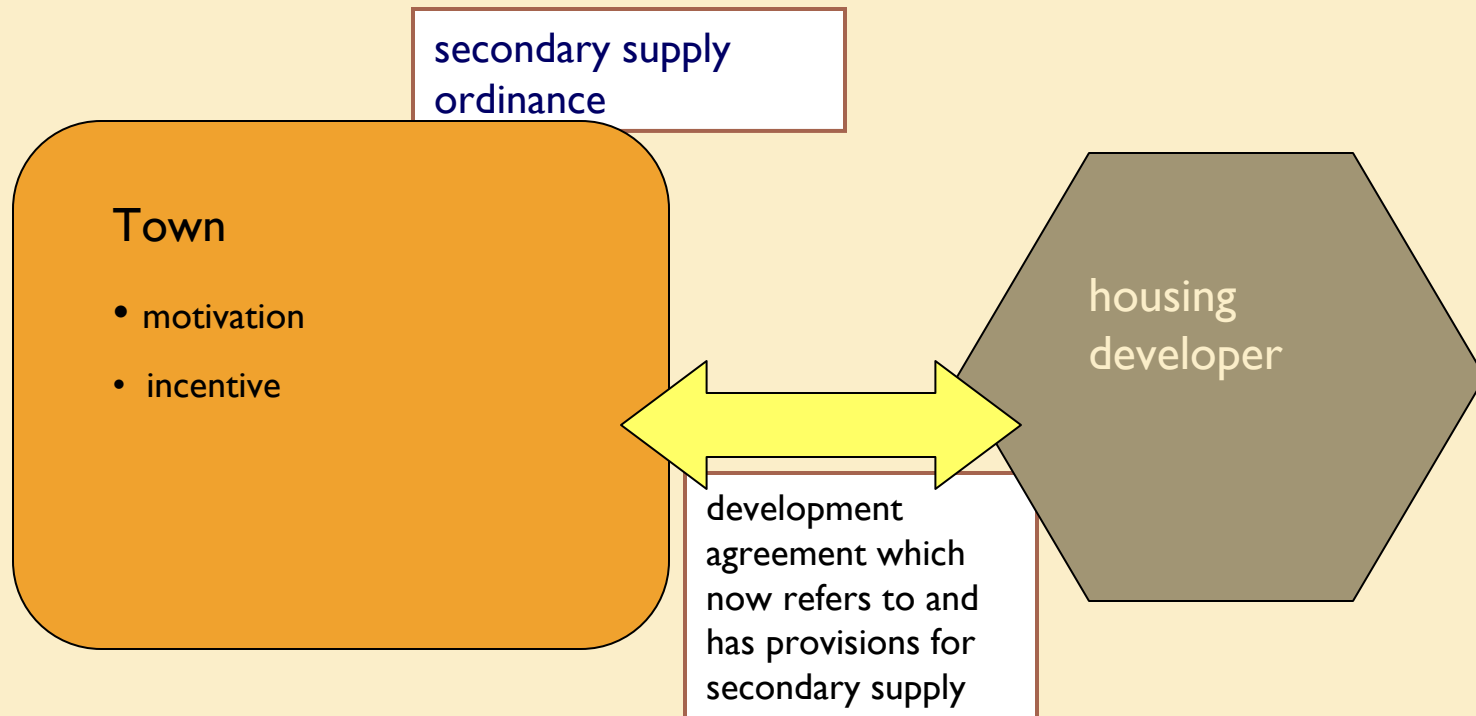

# All the intertwined agreements...

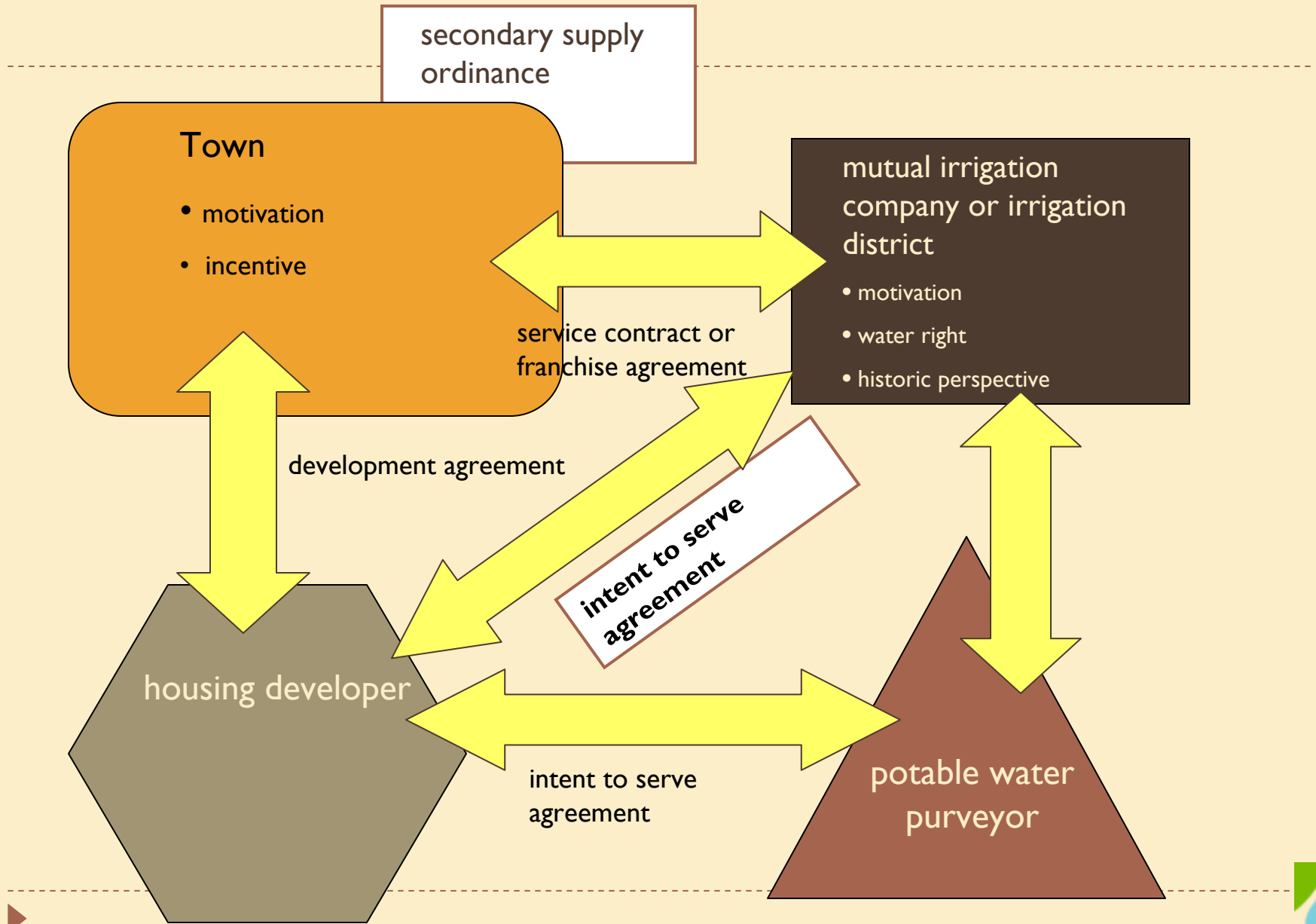



All makes sense!

---

So, is urbanization a **catalyst** for  
beneficial change?



# Yes...

---

- ▶ Secondary supply systems are coming to pass...**but**...most are individual housing projects (100 to 400 homes) and **regional systems are less prevalent**...

# Why?

- ▶ ... pitfalls or fatal flaws associated with intended regional systems are often more related to **sociological and political problems** as opposed to engineering problems ...



# Sociological and political elements

---

- ▶ Understanding the concept and the future
- ▶ Project cash flow
- ▶ Water rates
- ▶ Share ownership and control
- ▶ Risk assessment
- ▶ Long term O&M and ultimate replacement



# Case Study

- ▶ Highland Secondary Water Company
  - ▶ Phase participants
    - ▶ Development(s)
    - ▶ School district
    - ▶ Oversized infrastructure for others to come into the system

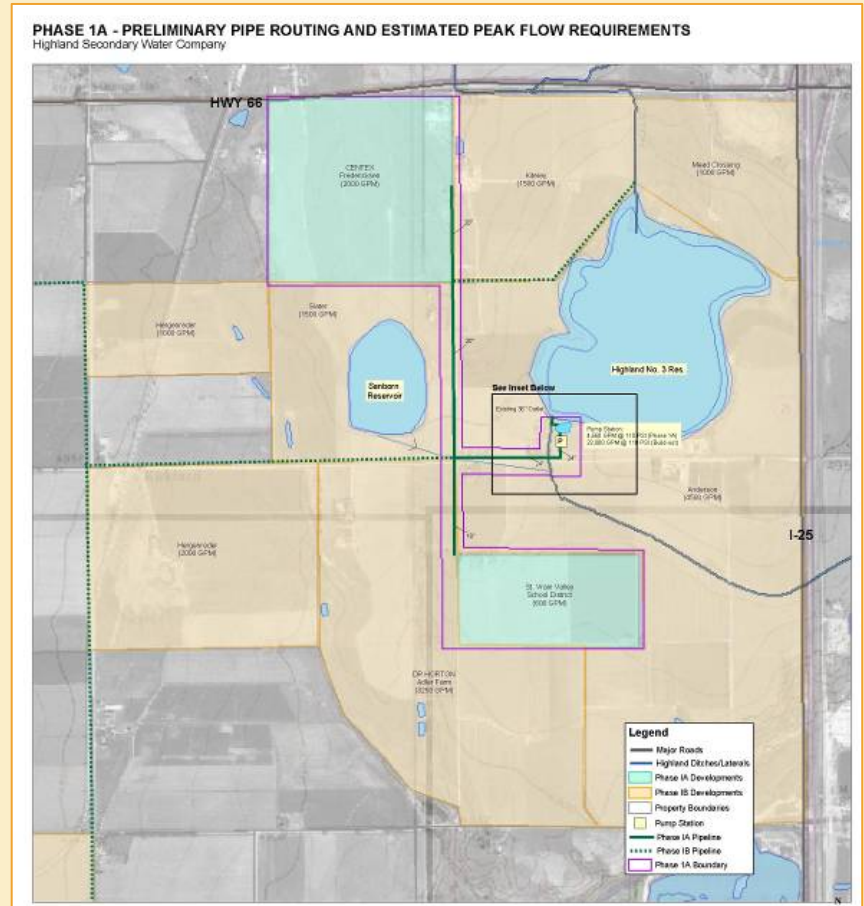

# Case Study

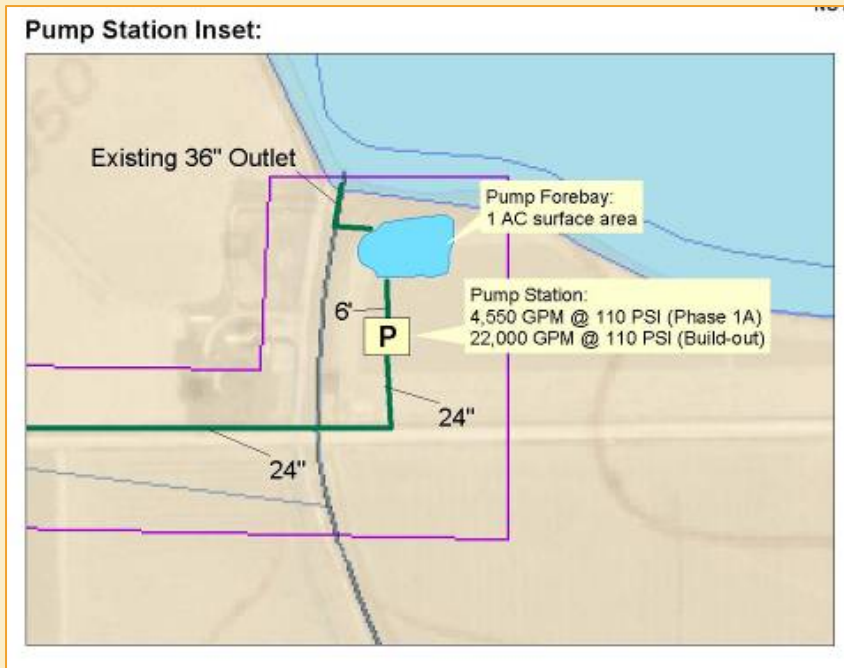

## ▶ Phase I Infrastructure

- ▶ Use existing outlet
- ▶ New forebay/pond
- ▶ Modular pump skid
- ▶ Oversized intake system
- ▶ Oversized building



---

Questions? Observations?

